



GAS	II2G Ex d IIC T6	IP 66	Zone 1 - Zone 21 - Zone 2 - Zone 22
DUST	II2D Ex tD A21 T85°C	IP 66	❄️-20°C ÷ ⚙️+40°C ❄️-20°C ÷ ⚙️+60°C

Materiale :	Corpo e coperchio e testa di lega leggera
Installazione :	N° 2 alette di fissaggio
Viteria :	Acciaio inox AISI 304
Guarnizioni :	+40°C EPDM , +60°C Silicone
Collegamento :	Morsettiera a bordo contatti
Ingresso :	N° 1 Ø 1/2"
Peso :	0,40 ÷ 0,50 kg
Material :	Light alloy cover, body and head
Installation :	N° 2 installation tabs
Hardware :	Stainless steel AISI 304
Gaskets :	+40°C EPDM , +60°C Silicon
Connection :	On board of contacts device
Cable entry :	N° 1 Ø 1/2"
Weight :	0,40 ÷ 0,50 kg

Tensione nominale :	Ui 690V
Corrente nominale :	Ith 10A
Frequenza :	50Hz + 60Hz
Morsettiera :	2,5 mm ²
Rated voltage :	Ui 690V
Rated current :	Ith 10A
Frequency :	50Hz ÷ 60Hz
Terminals :	2,5 mm ²
Corrente nominale Classe AC15	
Rated current AC 15 Class	
24Vac - 50/60Hz :	10A
120Vac - 50/60Hz :	6.0A
230Vac - 50/60Hz :	3.1A
240Vac - 50/60Hz :	3.0A
380Vac - 50/60Hz :	1.9A
Corrente nominale Classe DC13	
Rated current DC 13 Class	
24Vdc :	2.8A
125Vdc :	0.55A
250Vdc :	0.27A



Z11
Contatto standard Standard contact
A scatto Snap action
1NO+1NC

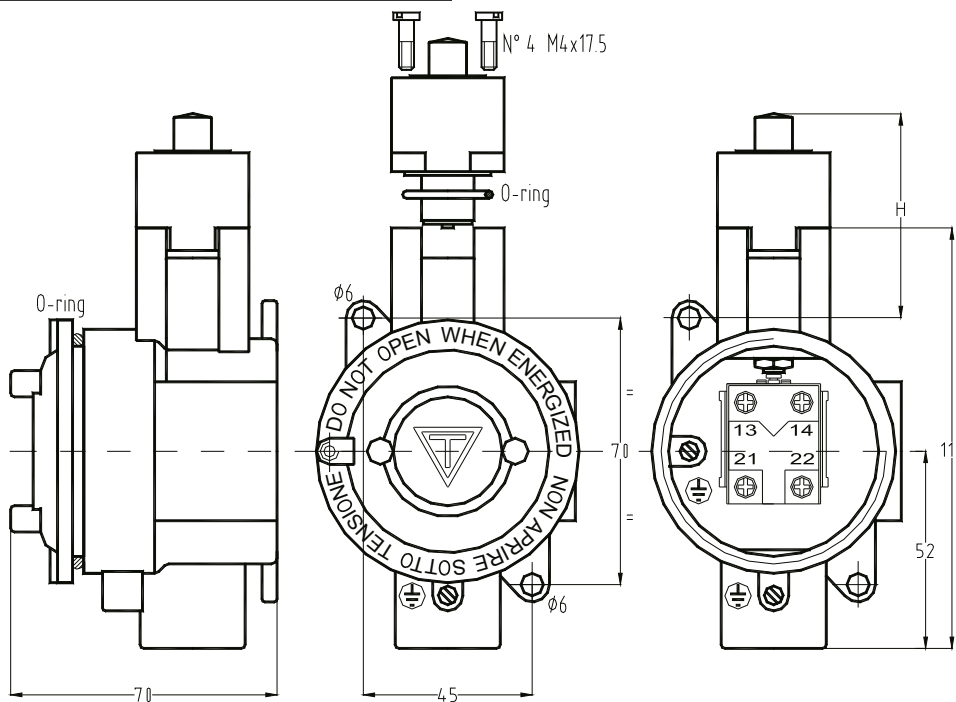

code	11	12	13	21	22	23	32	42	52	61	62	72	91	92	93	99
H [mm]	37	36,5	50	30,5	30,5	30,5	64	63	124	132	132	207	130	130	130	59,5

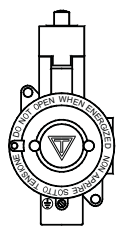

11

Pistone acciaio inox
Stainless steel piston



12

Pistone inox con sfera
s.s. piston with sphere



13

Pistone acciaio inox
s.s. piston



21

Pistone inox laterale
s.s. side piston

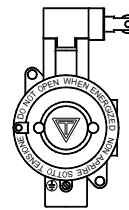

22

Pistone inox laterale-rotella
s.s. side piston with roller

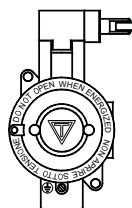

23

Pistone inox laterale-rotella
s.s. piston with roller

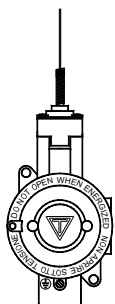

91

Multidirezionale a molla
Multi direction with spring



93

Multidirezionale a molla
Multi direction with spring

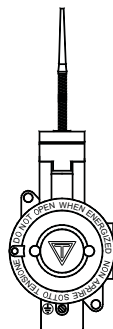

92

Multidirezionale a molla
Multi direction with spring

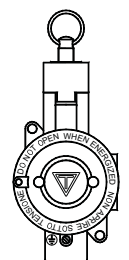

99

Con anello a strappo
With ring pull

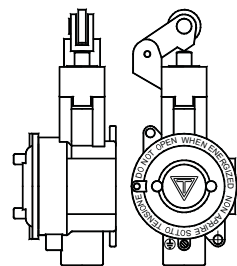

32

Leva con rotella
Lever with roller

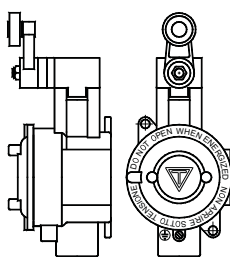

42

Leva con rotella laterale
Side lever with roller

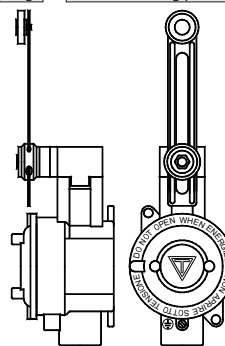

52

Leva con rotella laterale
Side lever with roller

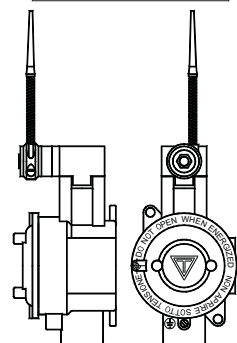

61

Leva a molla
Spring lever

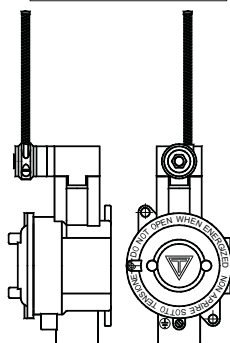

62

Leva a molla
Spring lever

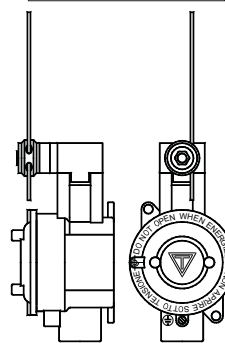

71

Asta regolabile acciaio inox
s.s. adjustable lever

X11	Y11	W02	W20	Z02
Contatto a richiesta Contact upon request	Contatto a richiesta Contact upon request	Contatto a richiesta Contact upon request	Contatto a richiesta Contact upon request	Contatto a richiesta Contact upon request
Azione lenta non sovrapposti Slow action not overlapped	Azione lenta sovrapposti Slow action overlapped	Azione lenta Slow action	Azione lenta Slow action	Contatti a scatto Snap action
1NO+1NC	1NO+1NC	2NC	2NO	2NC